

Installing the Product

Before you start here you should have looked at the 'Before You Install' details.

This is designed to help you with the vast range of trailers, winch platform variations, winch posts as well as the different types of boats.

- 1 Aligning the Trailer Rollers/Slides
- 2 Moving the Winch Post
- 3 Installing the Snare
- 4 The right Angle of the Latch to the Snare
- 5 Installing the Latch
- 6 Adjusting the Latch relative to the Snare
- 7 Trailer Sticker

For more information :- www.boatlatch.com

| Contact Us | Australia | International |
|------------|---|-------------------|
| Mob/Cell | 0402 079 660 | +(61) 402 079 660 |
| Web site | www.boatlatch.com | |
| Skype | geoffrey.c.davis | gd7214 |
| Email | boatlatch@internode.on.net | |
| By Post | Release & Retrieve Boat Latch Pty Ltd 17 Windjammer Court, Encounter Bay, SA, 5211, Adelaide, Australia | |



After looking at the 'Before You Install' details you will have worked out whether you need any variations to your trailer or need to purchase the "RHS Support" or "Wedge" to get the correct mount and Snare to Latch angle.

1 Aligning the Trailer Rollers/Slides

An important issue even for those without an L & R™ unit. The boat moves more easily on the trailer when it is properly aligned. The concept is..... align rollers/slides so that the centreline of the boat and trailer are the same - the boat should head for the centre of the Winch reel. The end result also will be that the boat will require less force to move it on or off the trailer.

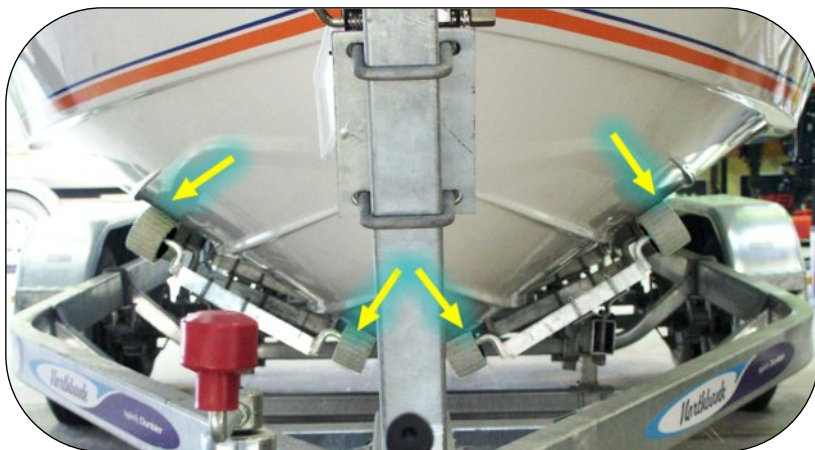

A Tip

Release the winch. The bow of the boat then should be lined up with

- tow point
- middle of winch post
- middle of the winch drum
- middle of the roller/v-block
- middle of bow of the boat.

If not check with the tape measure and follow the procedure shown here.



1 Aligning the Trailer Rollers/Slides..... continued

Centre line of Trailer, Boat & Winch reel

Rule is:-

(1) L equals R

(2) H_1 equals H_2

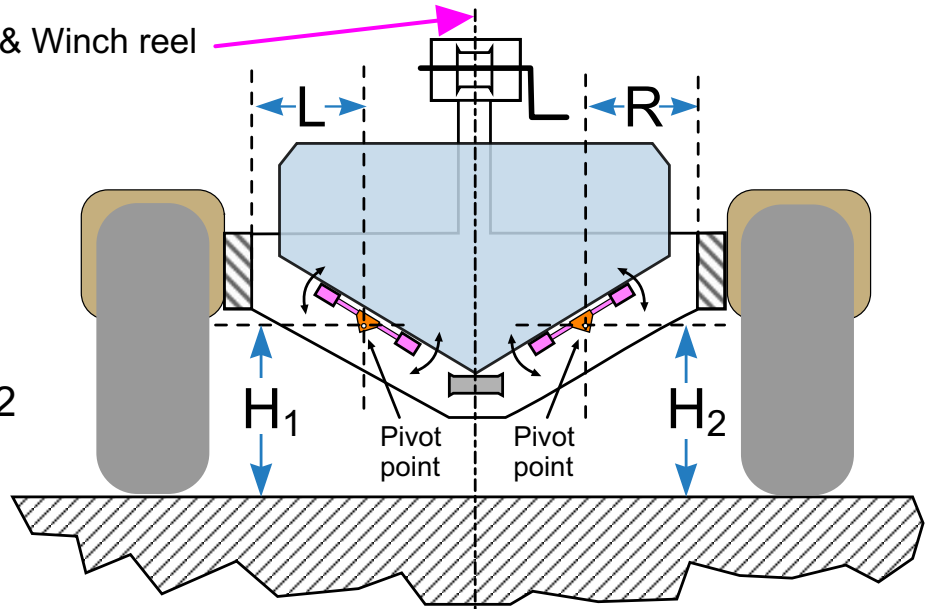

Essentially the boat needs to travel down the centreline of the trailer, with proper support from each side.

When this is right it will also glide far more easily on & off.

Make sure the trailer is on level ground.
The tires should be equally inflated.

The Boat must be 'aimed' down the Centre line of Trailer.

Measure in from the trailer frame to the Pivot point on each side (L & R), and the distance from the ground up to the Pivot points (H) of the rollers/slides.

Adjust so that $L=R$ and $H_1 = H_2$ if needed.

As the boat moves up the trailer's centreline it should be equally supported on each side.

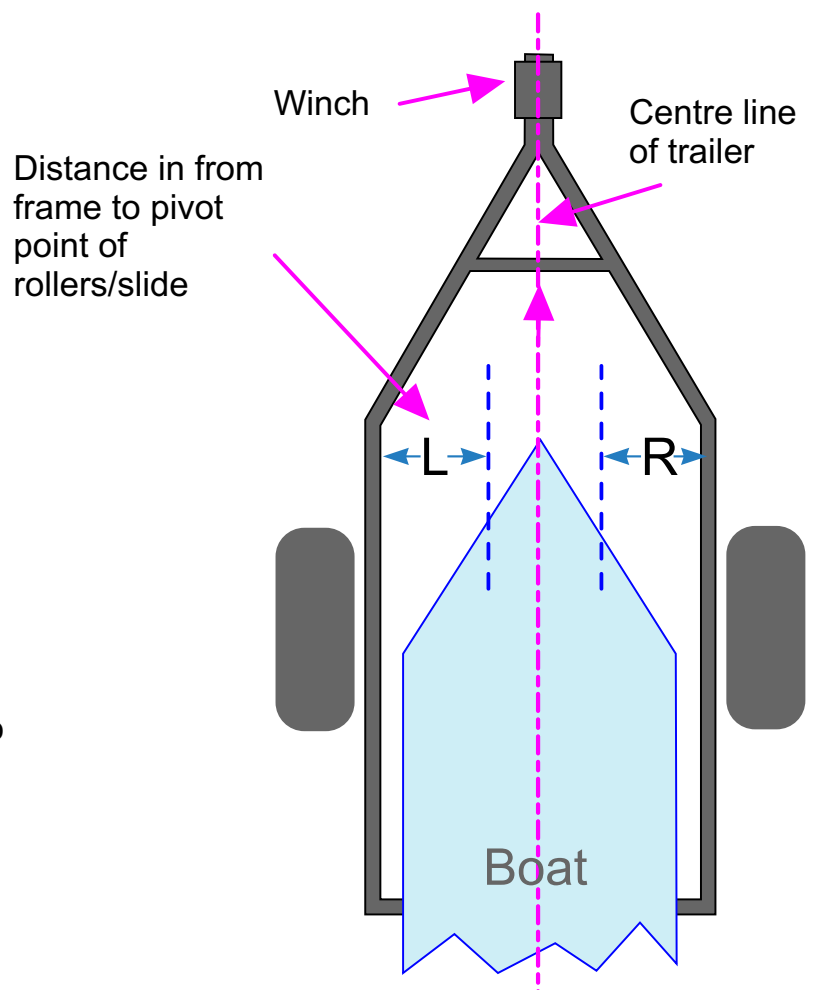

2 Moving the Winch Post



Loosen the bolts holding the winch post so you can slide it back out of the way.



This gives you plenty of room to replace the U-bolt on the hull with the Fibreglass Snare or mount the Aluminium Snare on the towing eye of an aluminium boat.

You can remove it altogether if required.

Where things go

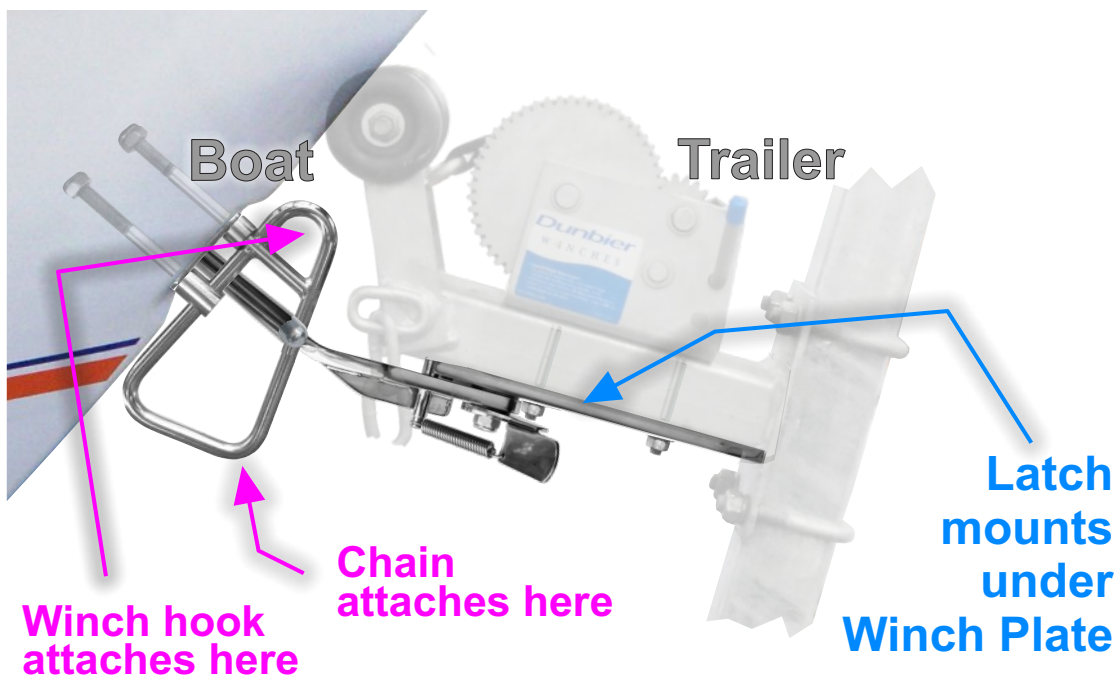

3 Installing the Snare The Snare needs to be fitted first.

Snare - U-bolt

For Fibreglass, Wood, Poly, Steel & Jet Ski boats. Product is commonly known as the 'Fibreglass Snare'). In the USA this can apply to U-bolt versions, where the U-bolt is used in place of an aluminium towing eye.

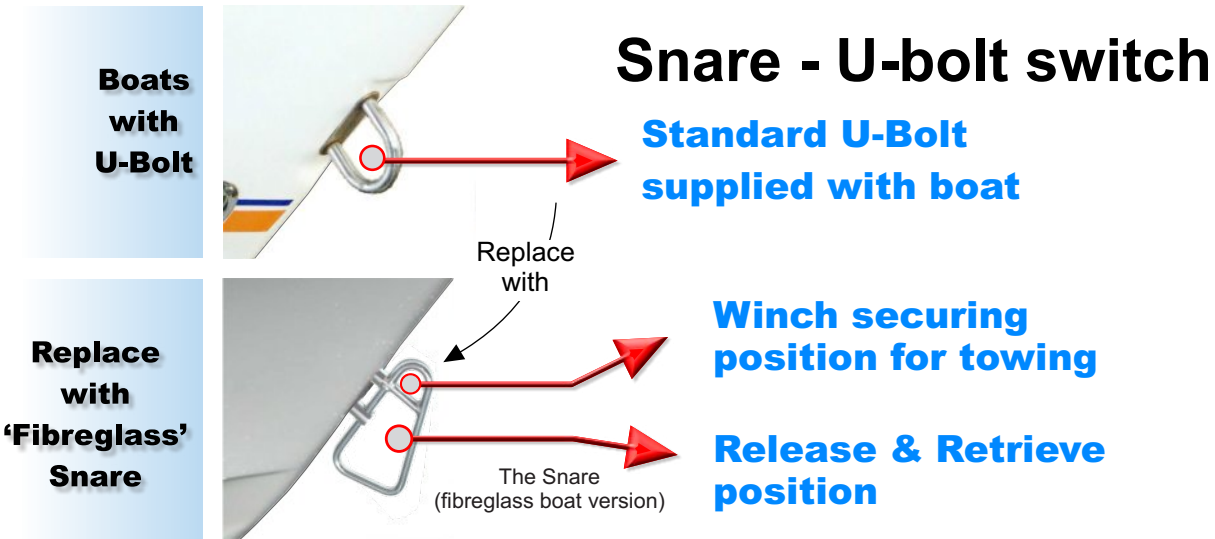

You may need to increase the size of the existing holes to suit 12mm (0.475") rod.

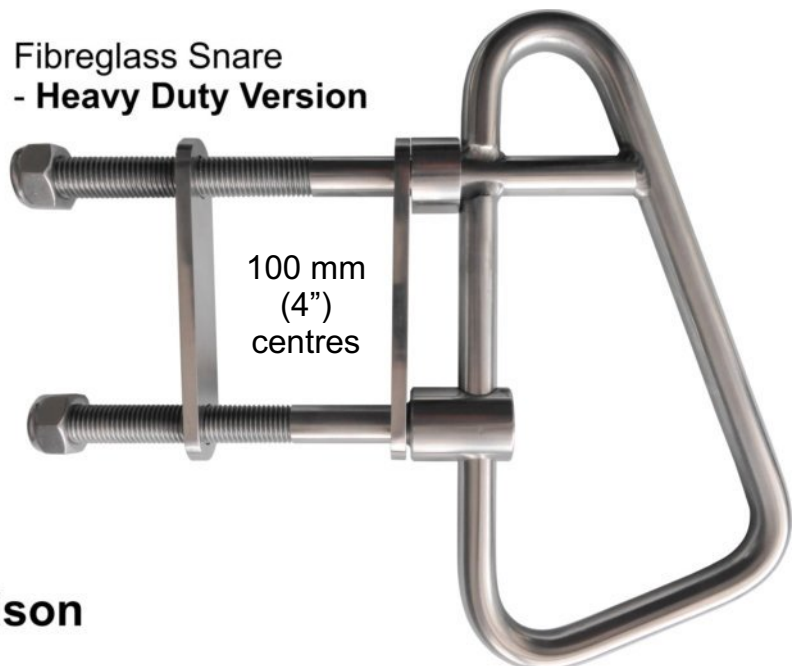
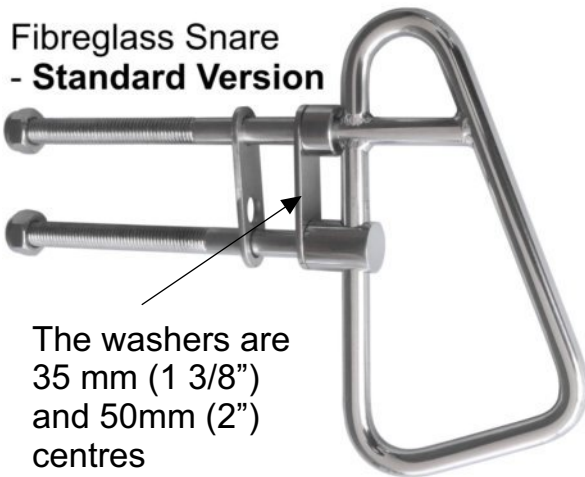

A relative size comparison

Heavy Duty Snare

Consider for boats over 6.5 metres (21 ft) and/or for very heavy duty end use applications.

3 Installing the Snare continued

● Snare - Standard U-bolt version ('fibreglass' snare)

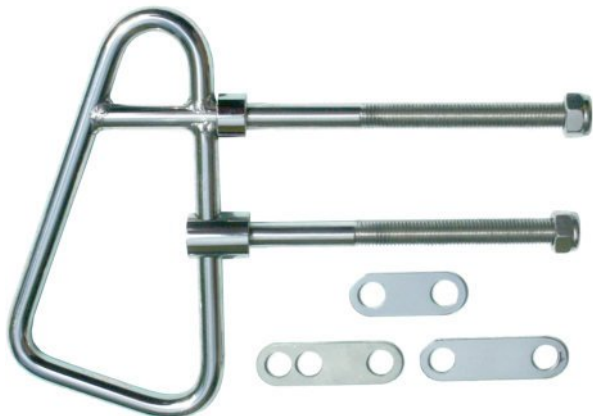

For Fibreglass, Wood, Poly, Steel & Jet Ski boats.

Product is commonly known as the 'Fibreglass Snare'.

Tested at 4.7 tonnes tensile strength.

Suggested max. boat size 6.5 metres (21 ft)

Check the bolt length you actually require, **before** installing. Measure (use existing U-bolt as a guide) and cut off **surplus** and then file the end to allow an easy nut start.

Clean off the threads and lightly grease. (stainless is prone to locking up - so be careful)

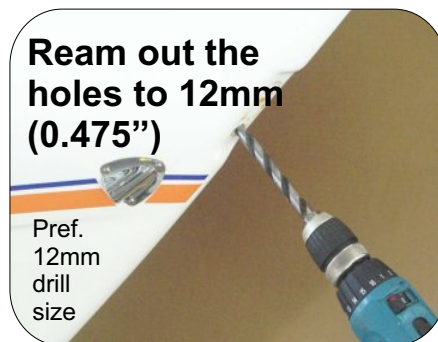
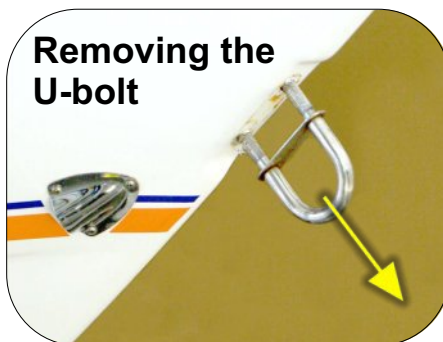

Marine grade silicone application

Select the right sized spacer washer. Place the polished one on the snare, and apply silicone to seal the hull when mounted.

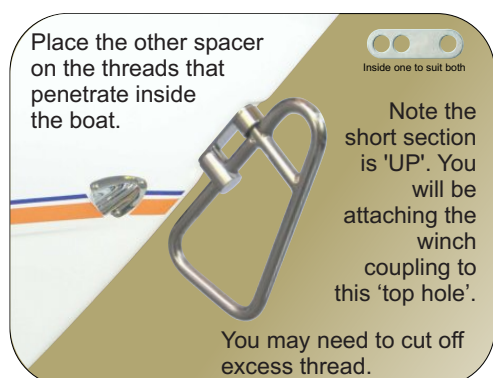

Firstly install the snare - on the Fibreglass boat

Insert the snare into the holes. Note the short section is "up". You will be attaching the winch hook to this 'top hole'.

Place the other spacer on the threads that penetrate inside the boat. Lightly grease then tighten the nylon locking nuts onto each thread.

Note stainless is notorious for locking up - always grease threads.

3 Installing the Snare continued

Snare - HEAVY DUTY U-bolt version ('fibreglass' snare)

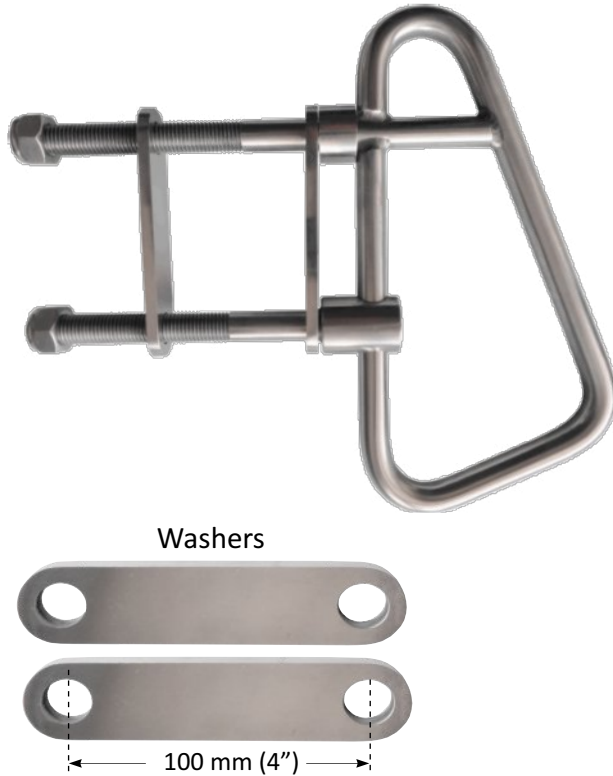

Boat size 6.5 metres (21 ft) and above.
Tested at 7.5 tonnes tensile strength.

This big version will fit on U-Bolt boats (Fibreglass and some Aluminium boats in the US).

For U-Bolt boats, remove the U-Bolt and silicone up the bottom hole.

Drill out top hole to 16mm (5/8" +) and use one of the washers as a template drill guide for the bottom hole. Measure (use existing U-bolt as a guide) and cut off **surplus** and then file the end to allow an easy nut start. Clean off the threads, and lightly grease. (Stainless is prone to locking up).

Place one washer on the snare and apply marine grade silicone to the top un-threaded end of the threaded rods and a small amount to the front end of the mounting holes.

Apply silicone to the back of the front washer and bow location where it mounts, to ensure a good seal.

Insert the unit, and place the other washer on the back inside the bow. Tighten, remove excess silicone and clean up the rest with mineral turps.

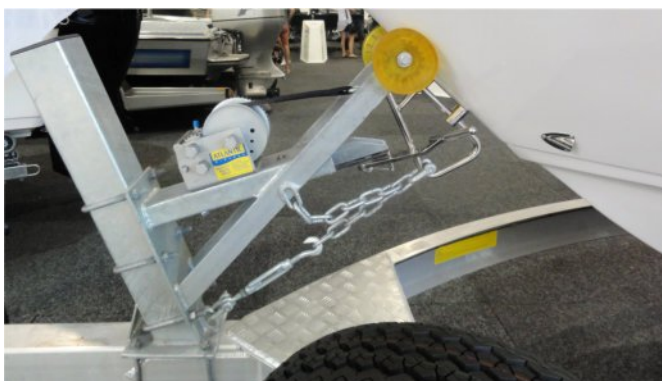

Here is an example of a Heavy Duty U-bolt Snare. A point to note here is that the Latch is mounted in this set-up with a Latch Support. It is not the standard one but reaches out to support of the front of the latch, which could bend on impact if not held firmly.

3 Installing the Snare continued

Installing the Snare - on Towing Eye (Aluminium) boats



Towing Eye version (usually aluminium boat)

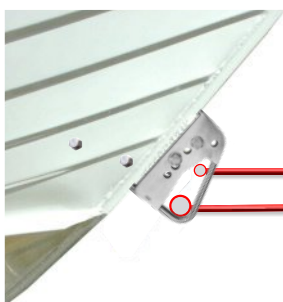

Winch securing position for towing "Aluminium" boat Snare (towing eye snare version)

Some Snare Towing Eyes

| QUINTREX | BROOKER | STESSEL | STABI Heavy Duty* | STABI normal | SAVAGE | BLUE FIN | BAR CRUSHER | STACER | HORIZON |
|----------|---------|---------|-------------------|--------------|--------|----------|-------------|--------|---------|
| | | | | | | | | | |

*Too thick to mount. Remove & use the Fibreglass Heavy duty Snare with backing plate.

A relative size comparison

Standard Towing Eye (Aluminium boat) Snare (V-6)
Tensile Strength = 5.5 tonnes

Heavy Duty Towing Eye (Aluminium Boat) Snare Version
Tensile Strength = 5 tonnes

Hole for shackle

Mount Heavy Duty unit attaches to 20 mm bow plate towing eye.

Dimensions:
120.4, 86.5, 59.5, 44.1mm, 18.8, 82.7 mm, 16.8, 20.9, 29.5, 31.9

3 Installing the Snare continued

Installing the Snare - on Towing Eye (Aluminium) boats

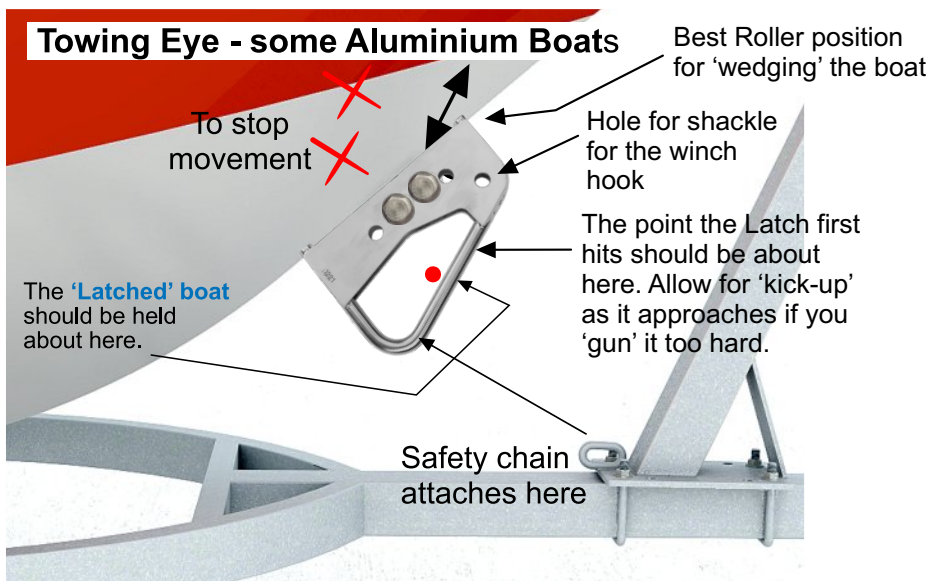

There are 4 possible mount holes which allows for an upper and lower position and washers to use to pack either side to clamp onto the towing eye, depending on its thickness. You don't have to use the washers if they won't fit.

Heavy Duty Towing Eye (Aluminium boat) Snare

For a large Towing Eye (Aluminium) boat or a very heavy duty application, Release & Retrieve Boat Latch Pty Ltd have the Heavy Duty version (see below) intended for boats over 6.5 metres (21 ft) or boats with very heavy duty end use.

This is suitable to be mounted on up to 20 mm thick towing eye plate.

As common with Aluminium boats you may need the Roller Extender option, if the winch post is sloped too far backwards from the bow. The extender allows the roller to be easily adjusted forward.

Details of the Roller Extender option (shown at the right) are covered a few pages further on here.

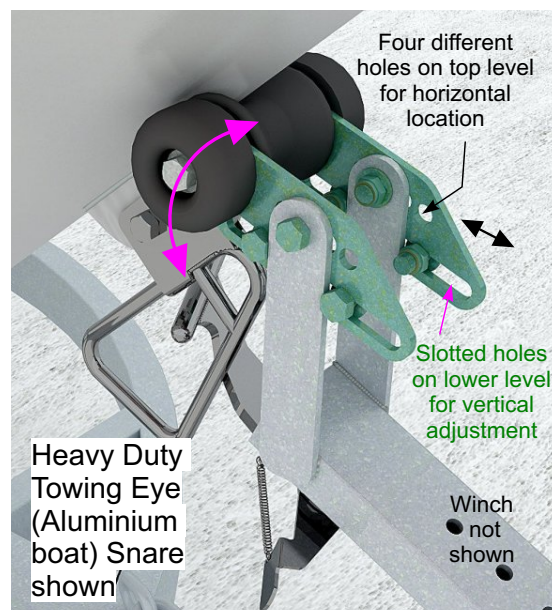

Roller Extender parts highlighted in green
See details several pages further on

4 The Right Angle of the Latch to the Snare

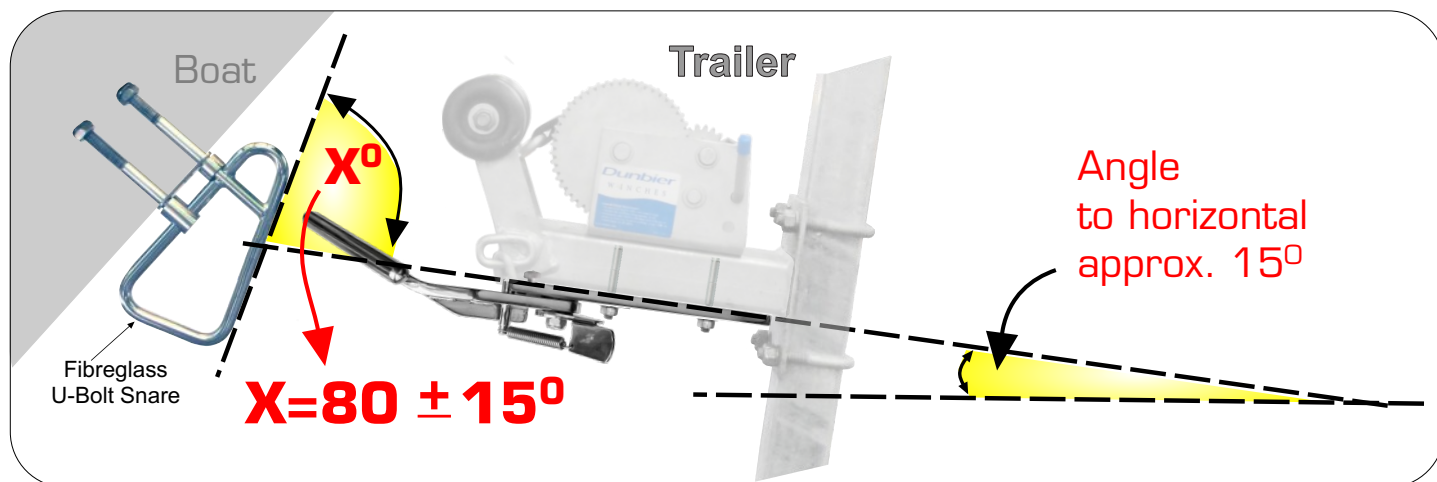

The key issue in getting good performance with the L & R Boat Latch is to have the correct angle where the Latch meets the Snare.

You need to roughly measure this angle. See guide... next page.

There are some odd winch plate and winch posts out there.

If the angle is not right you can adjust it using the “Wedge” or change the winch plate or the winch post to a different type. See ‘Before You Install’ document for more details.

Typical examples where you may have an issue with the Snare/Latch angle



Examples where the ‘Wedge’ would sort out the angle problem. The ski boats are about 58 to 62° which is too low, and the ‘Wedge’ will bring them nicely into the right operating range.

To overcome the reaction between stainless steel and the aluminium, smear a coating of Duralac* as corrosion protection.
Fit the bolts and tighten nuts properly.



*Duralac is an anti corrosive jointing compound which prevents electrolytic corrosion between dissimilar metals. Available from a number of marine component dealers.

We have a template on the next page to make it easy to sort out the angle.
Print that page... and cut out where shown with some scissors.
Hold this up against the snare. Fold up or down the 15° increments, whether your angle is OK, or whether you need to take one of the 2 options.

Patented

4 The Right Angle of the Latch to the Snare continued

Paper cut out to measure angle.
Use scissors to cut where shown.

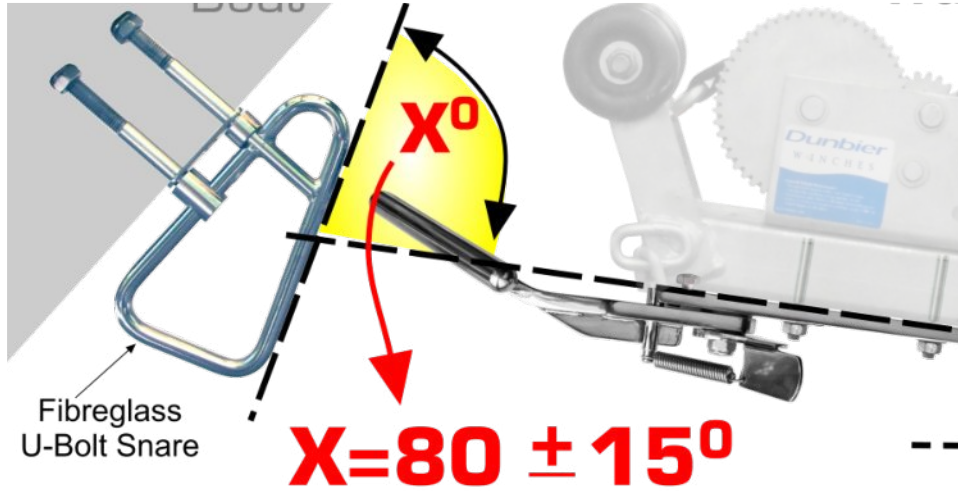

- (1) Cut out following the green line shown
- (2) Use shape to determine angle
- (3) Fold up or down the 15° sections to cover 65° (fold up) and 95° fully extended

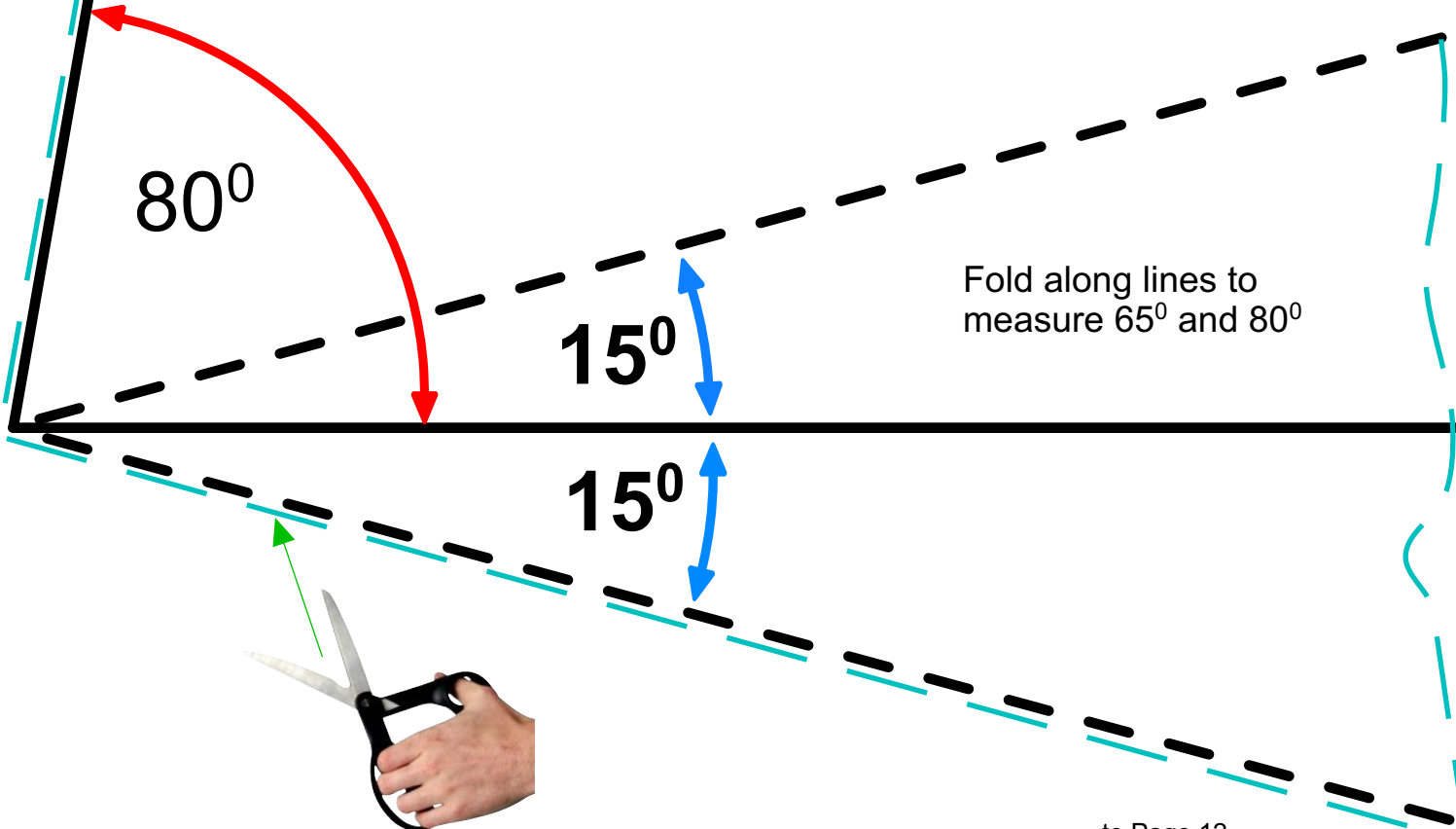

4 The Right Angle of the Latch to the Snare continued
If the angles are not right there are 3 options.....

To Adjust Angle using Wedge Kit



This allows you to..... adjust angle Up or Down 14°. The Latch Support part also allows you to mount the front of the Latch properly in some cases..... see under Latch installation.

This is a fast and simple way of altering the Latch angle.

▶ Tilt 14 degrees DOWN



Note - a side benefit of using the ‘Wedge’ is that it can provide a support for the front of the Latch.

▶ Tilt 14 degrees UP



The bolts are not supplied as there are cases where you may use 4 short bolts or 2 longer bolts to mount the Wedge plates. Depending on the winch bolt positions.

[a] Replace the Winch Post or Platform (from Australian source)

To Adjust Angle using different Winch Post/Winch Top

Trailer manufacturers have a range of winch posts & tops.

If you have one like this,

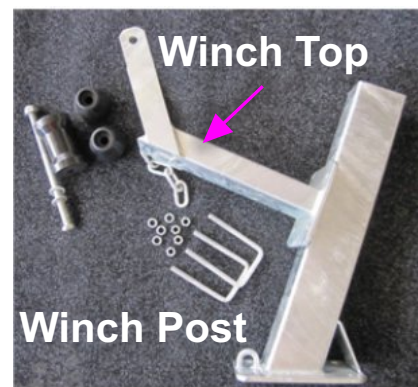

Example ... here is an Easytow Boat Trailer options...made for the Boat Latch.

[More Detail >](#)

4 The Right Angle of the Latch to the Snare continued

[b] Replace Winch Post or Platform (from USA source)

Your decision here will involve the width and depth of the winch post, and the height of the post. Then a suitable winch platform that will fit the post, that is suitable to mount the latch and winch.



More Detail >



More Detail >



More Detail >



More Detail >

Brackets & fittings separate here



More Detail >



More Detail >



www.boattrailerparts.com

More Detail >



www.sturdybuiltonline.com

More Detail >



www.boattrailerpartsplace.com

More Detail >



www.easternmarine.com

More Detail >

[c] How to make your own Winch Post and/or Winch platform ?

We provide all the details for manufacture of a suitable units. See details under 'Installation' on website under Component Detail. The sub-heading is 'Right Winch Post & Winch Platform'

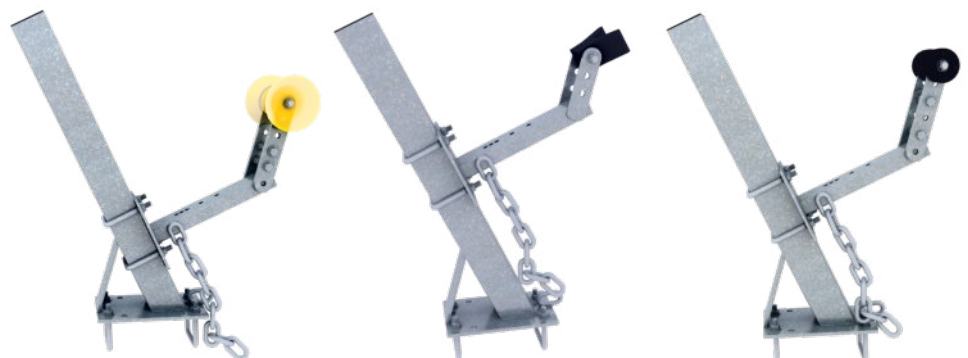

5 Installing the Latch

The trailers come in a wide range of styles. A typical one is shown on the right here. In reading 'Before you Install' this issue is raised in detail. Latch is bolted underneath the winch platform.

It is important that the latch is fully supported - not just hanging out in space. An impact (say with the wharf) can bend the latch Base Plate. Where there is no support we have the 'Latch Support' which is part of the 'Wedge Kit'.

Here we see a quite different style of winch post, where a latch support (not our standard one) has been inserted into the tube section under the winch and bolted. This allows the **front bolt** on the Latch to be bolted to it, provided sturdy support. **Without this bolt you will void the warranty.**

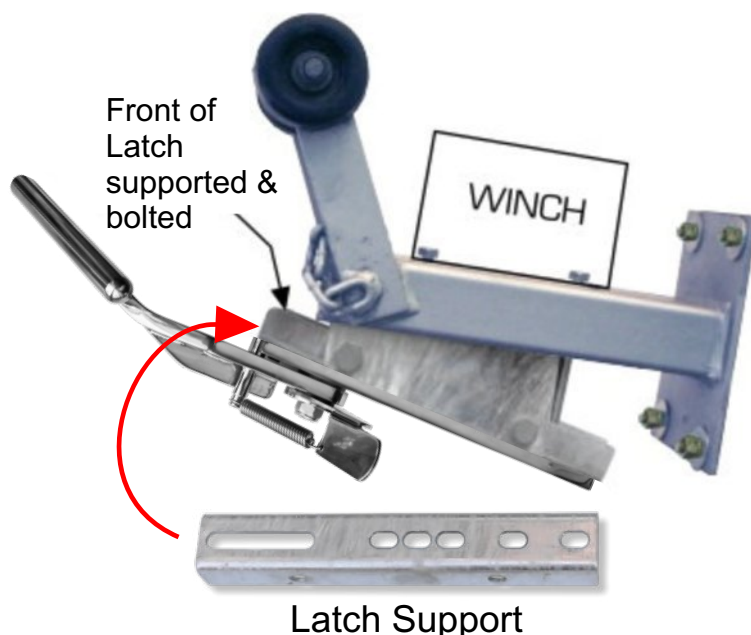
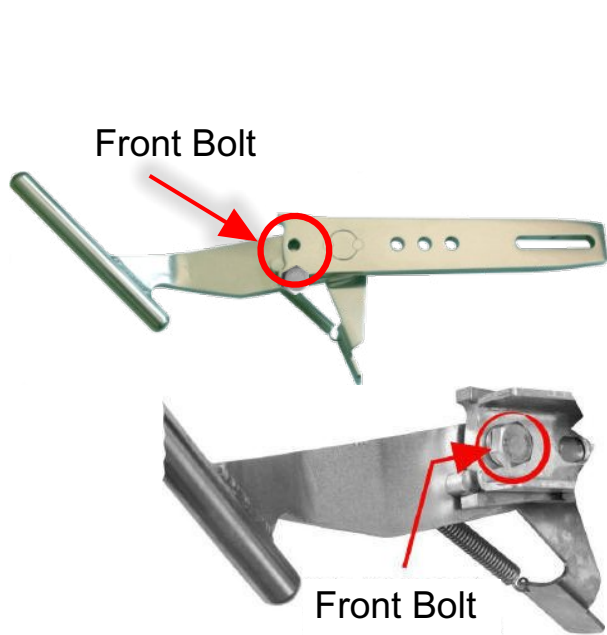
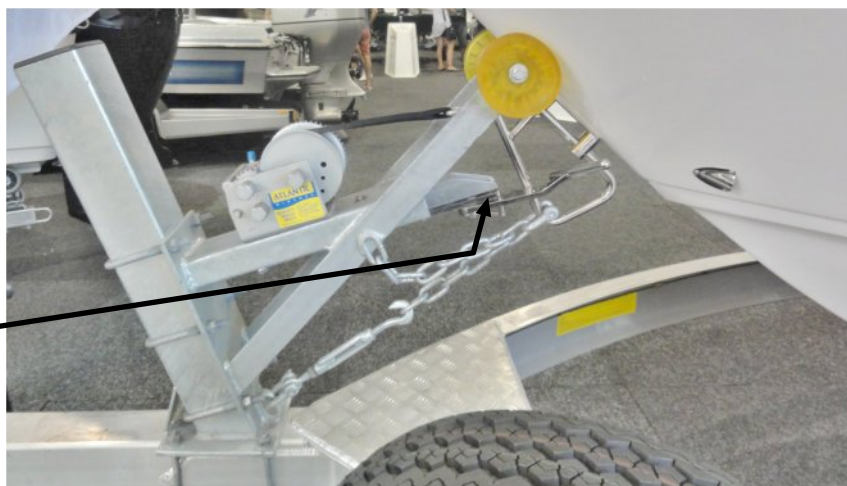
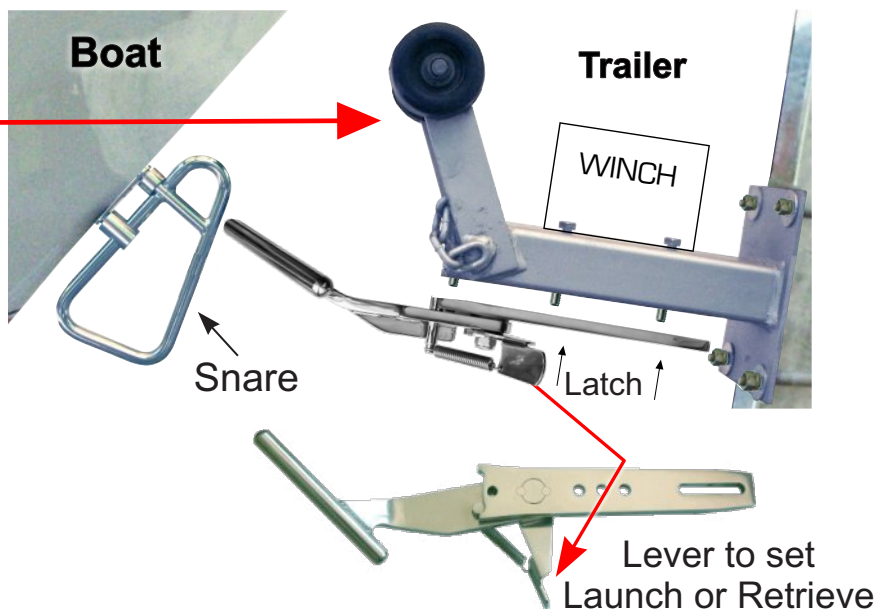

5 Installing the Latch continued

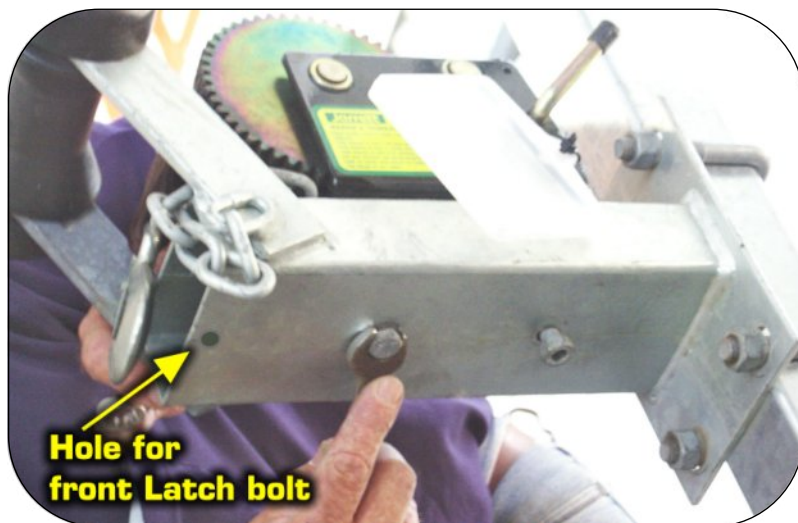

Removing the Winch bolts & bolting on the Latch

There are a variety of winch types out there - the one shown here is a very simple one. Some need more than 2 bolts and hi tensile ones - Check the suppliers's requirement. You will need to drill a hole for the front latch bolt.

Longer versions of the same winch bolts may be required to reach through the latch plate.

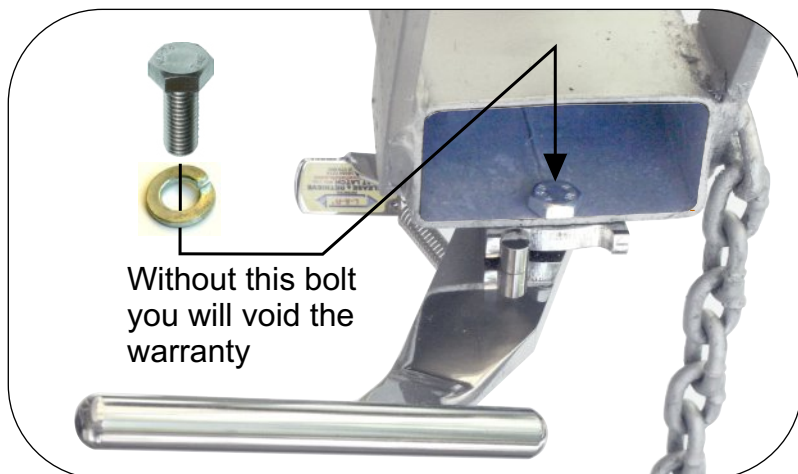

Remember front Latch bolt

The front of the latch must be properly held by a bolt (provided).

In the event of an extreme impact the latch base plate could be bent if not secured here.

Without the bolt you could void the warranty.



Clearance for Shift Lever

Trim bolt end if, required, so there is clearance for Shift Lever to move.

Spring Washers for bolts

Remember to use spring washers on bolts, and /or nylon locking nuts so they won't work loose.



A Top view of the Latch

At the middle of the latch there is a choice of holes to set the latch forward or backwards on the winch base. Engage one of these and check that when the winch post is moved forward (to the final position) that the latch will properly engage with the snare. See 'finger test' below.

6 Adjusting the Latch relative to the Snare

Where the latch should meet the Snare ?

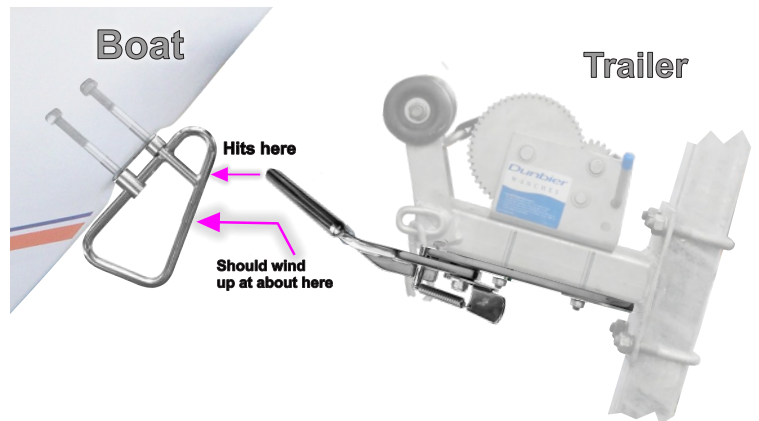

Fibreglass Boat

- 1 - No gap between roller & bow.
- 2 - Adjust [a], [b] & [c] so that the gap [f] between the Snare and the bar on the Latch = 1 thumb width (25 mm or 1")

Use a G-clamp to hold the Latch, under the winch plate to find the best location.

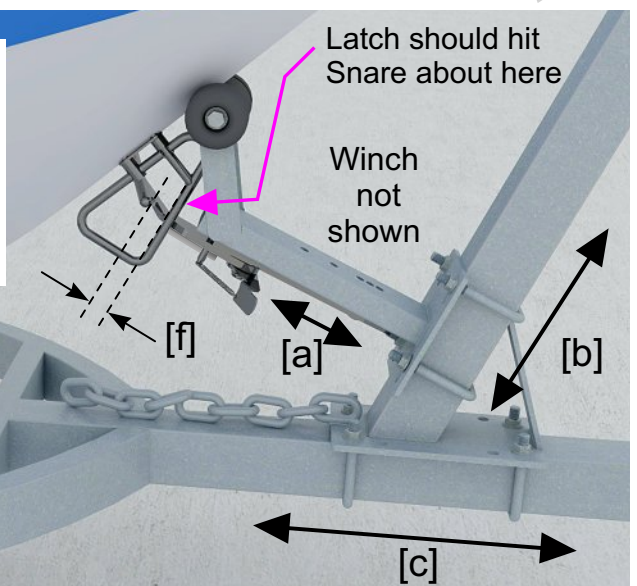

When roller/wedge is right up against the bow

[f] = 1 thumb widths (25 mm or 1")

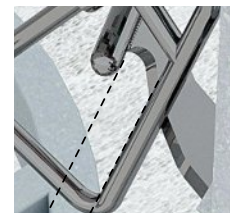

Towing Eye (Aluminium)

- 1 - No gap between roller & bow.
- 2 - Adjust [a], [b] & [c] so that the gap between the Snare and the bar on the Latch = 1 thumb width (25 mm or 1").

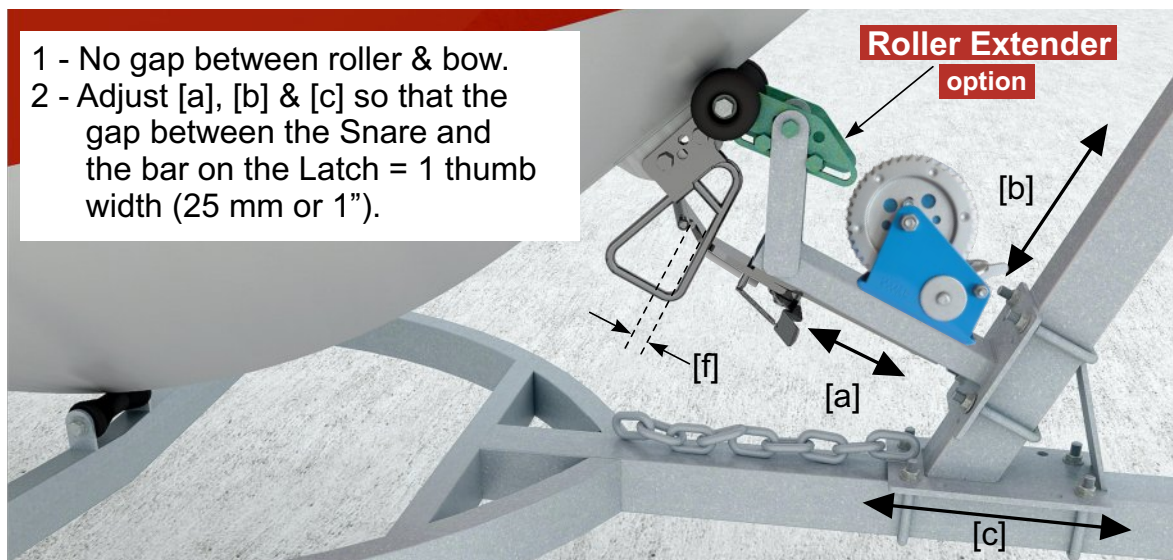

Example - If this winch post was not as laid back, the roller would be closer to the bow and extender would not be required.

6 Adjusting the Latch relative to the Snare - continued

Roller Extender - Option



Roller Extender - option

Used where the roller needs to be able to **project out further** to the bow. More commonly required on Towing Eye (Aluminium) boats and with HD snares.

Endless variation of boats and trailers, results in the inability to get the roller in the best position sometimes.

The option needs you to provide 6 M12 galvanised bolts with washers and nylon locking nuts.

Adjustment ability

There are 4 adjustment horizontal positions. The bolts locate in one of these and the other pair of bolts go in slotted holes, allowing the roller/wedge to swing up/down for vertical adjustment.

The 2 lower bolts are fixed so that the bolt or nut heads are located against the vertical Roller supports of the winch platform, as shown, limiting movement.

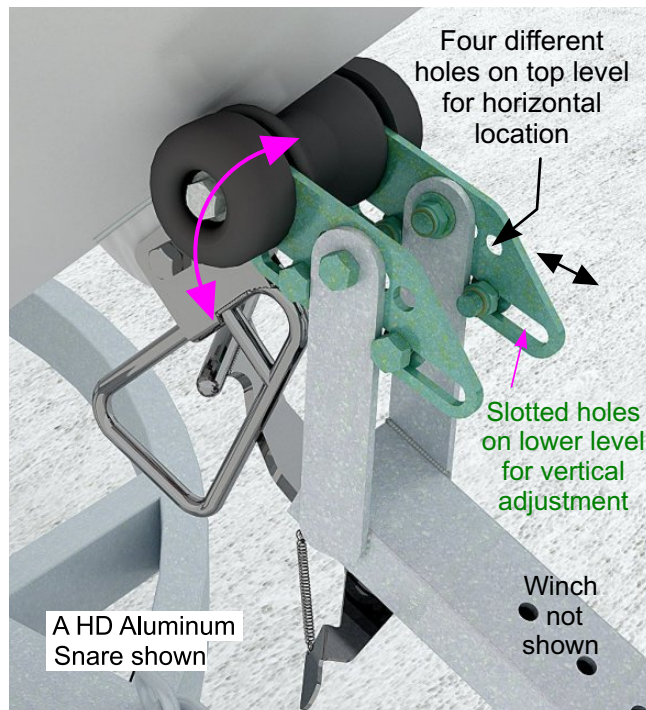

Roller Extender parts highlighted in green

Example

Here is an example on an Aluminium Towing Eye boat where the roller should be further forward.

In this case the snare is very close to hitting the winch platform when the roller is against the bow. The roller should be where the red dot is shown on (2).

The standard finger gap [f] should be a thumb width and this is about 4 fingers.

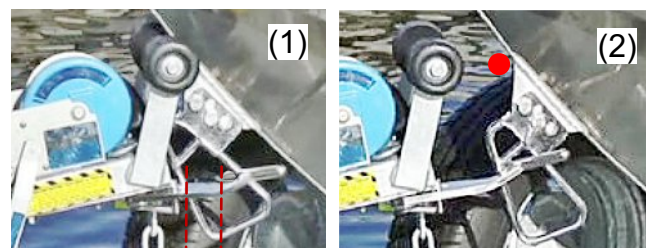

[f] → | | ←

HD Snare shown

Helping to limit boat movement on the trailer

Your boat should be securely held on the trailer, to restrict UP & DOWN movement (even though the winch is tensioned up) whilst being transported. There is a lot of weight here and you need the boat secured when moving at highway speed.

A classic way of avoiding the issue is to have the roller 'wedging' the boat, as shown here for the two different boat types.

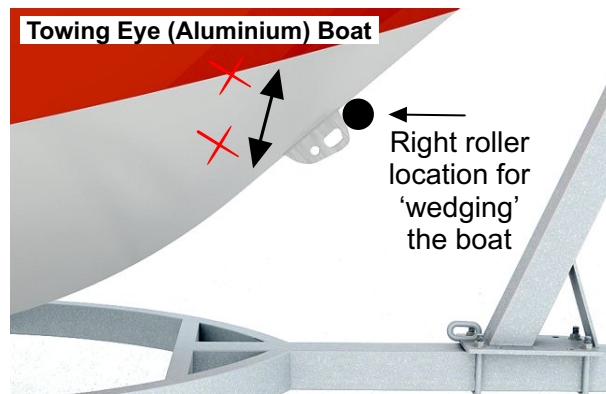
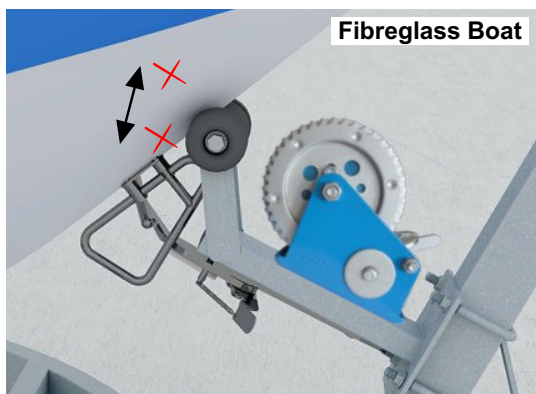

6 Adjusting the Latch relative to the Snare continued

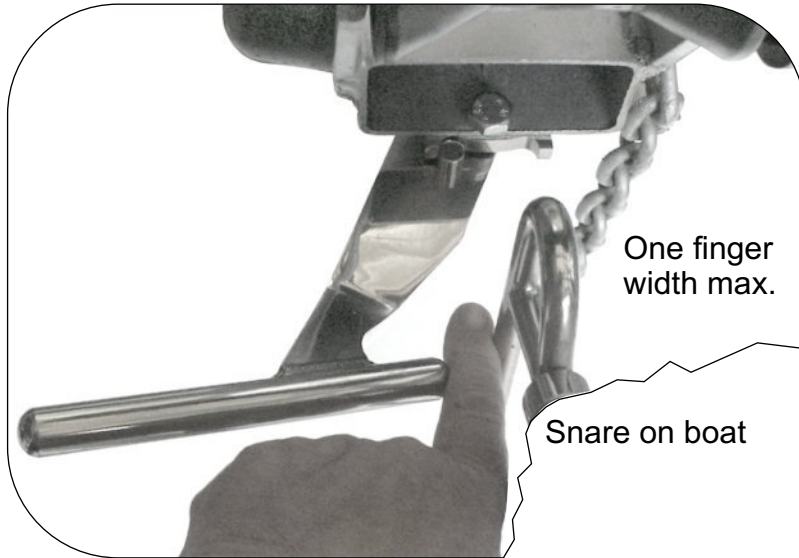

'Finger' Test [2]

The Latch should move aside to give a finger spacing as shown in the photo.

Note: the Snare, on the boat should be central - if it is not the boat may not be centrally aligned on the trailer. See Step 1.

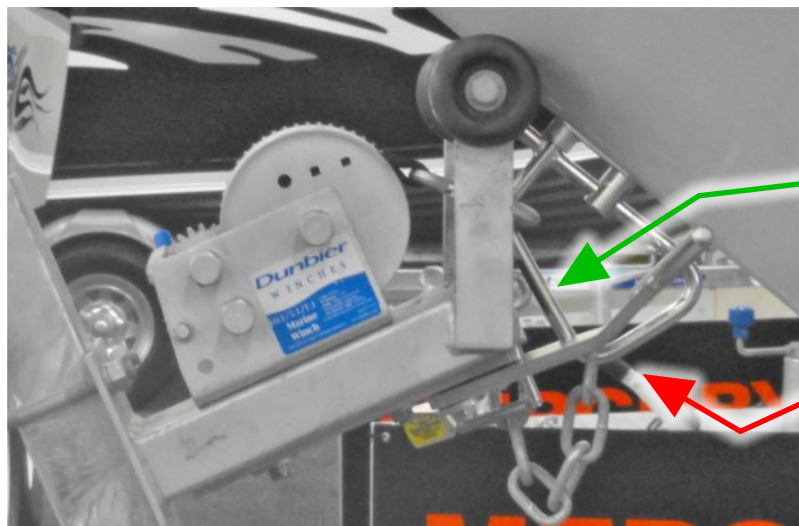

Latch - Getting the Right Height

Latch should wind about here.

An example showing where the latch has been set too low.

Tighten up all the nuts & bolts



Having the correct position for the Latch, tighten all the nuts & bolts up **securely and with even tension.**

7 Place the Sticker on the Trailer

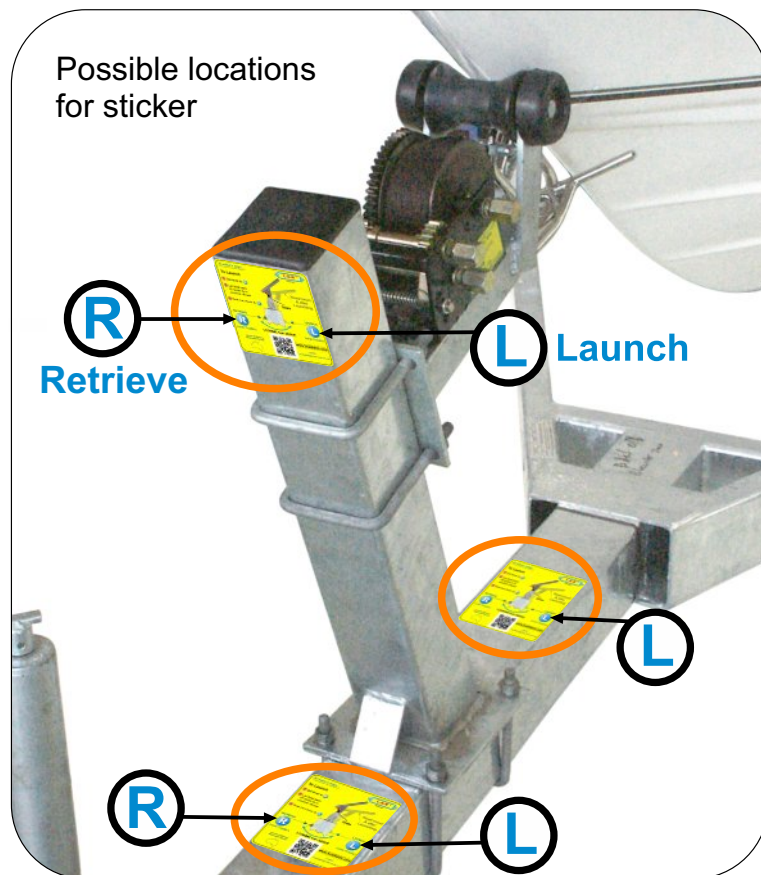

A special weatherproof sticker is included in the pack to place on your trailer.

The sticker is your guide to which side of the trailer you need to move the Shift Lever to in order to **launch** or **retrieve** your boat.

Three possible locations are shown on the photograph.

It is most important to remove all salt, dirt, grease, **before** fixing the sticker.

Note : The latch should be disengaged for road travel. When traversing boat ramps **NEVER** rely on the latch to hold the boat to the trailer.

Safety chains and the winch cable/straps should always be used to secure the boat to the trailer.

Do this **before** driving up to the car park, otherwise you will forget and wind up driving down the road.

Using the Product - *Key Tips*

- **'LAUNCH'** - the boat **MUST** be **UNABLE** to float off the trailer - there is resistance from rollers/slides, & the latch is holding the front of the boat.
- **'RETRIEVE'** - have the trailer the same depth as a 'good launch'. If it is too deep (a common mistake), the approach speed will be high & the equipment may be damaged.

